

# Immersible Thermal Gas Mass Flow Meter

## Features

- Direct mass flow monitoring eliminates need for separate temperature and pressure inputs
- Accuracy +/- 1% of reading plus 0.5% of full scale
- Patented Dry-Sense™ technology eliminates sensor drift
- State-of-the-art calibration facility insures a highly accurate calibration that matches the application
- Field validation of meter electronics and sensor resistance verifies flow meter performance
- One-second response to changes in flow rate
- FM, CSA, PED, ATEX and GOST R/RTN certified for hazardous areas
- CE approved
- High temperature option to 750F (400C) available
- Multipoint options available
- Integrated self-cleaning purge option available for dirty flows
- Low and high pressure hot taps available
- Optional MODBUS, Foundation Fieldbus and Profibus PA available



SIERRA INSTRUMENTS, NORTH AMERICA • 5 Harris Court, Building L • Monterey, California • (800) 866-0200 • +1 (831) 373-0200 • Fax: +1(831) 373-4402

SIERRA INSTRUMENTS, EUROPE • Bijlmansweid 2 • 1934 RE Egmond a/d Hoef • The Netherlands • +31 (0) 72 5071400 • Fax +31 (0) 72 5071401

SIERRA INSTRUMENTS, ASIA • R.m.618, Tomson Centre, Building A • 188 Zhang Yang Rd • Pu Dong New District, Shanghai, P.R. China 200122 • +8621 5879 8521/22 • Fax +8621 5879 8586

For information online: [www.sierrainstruments.com](http://www.sierrainstruments.com)

# Steel-Mass™ Model 640S



## Description

Sierra Instruments' Steel-Mass™ Model 640S immersible thermal mass flow meter is designed for the toughest industrial gas flow measurement applications.

The versatile microprocessor-based transmitter integrates the functions of flow measurement, flow-range adjustment, meter validation and diagnostics in either a probe-mounted or remote housing. Mass flow rate and totalized flow, as well as other configuration variables, are displayed on the optional 2 x 12 LCD display. The programmable transmitter is easily configured via an RS-232 communication port and Sierra's Smart Interface™ software, or via the display and magnetic switches on the instrument.

Sierra's state-of-the-art calibration facility insures that the calibration will match the application, and our patented Dry-Sense™ thermal sensor insures the Model 640S will hold this calibration over time.

Sierra's Smart Interface™ software guides you through a procedure to fully validate instrument performance, thus field-verifying meter functionality.

The meter is available with a variety of input power, output signal, mounting and packaging options.

The information contained herein is subject to change without notice.

## Hazardous-Area Location Enclosure Dimensional Specifications

### Compression Fitting—Side View (E2)

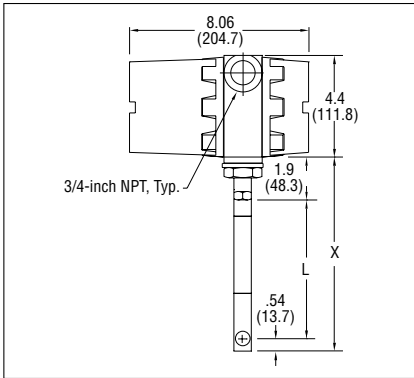

### Compression Fitting—Front View (E2)

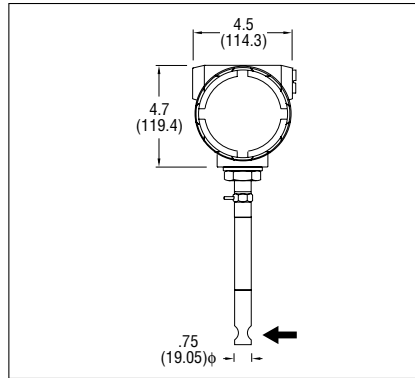

### Flange Mounting—Side View (E2)

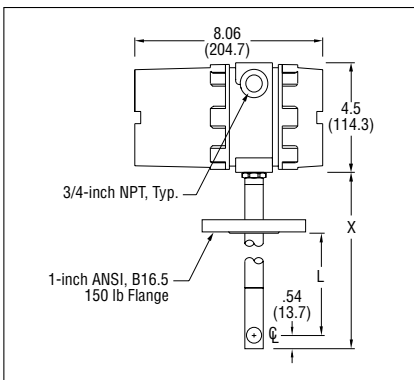

### Flange Mounting—Front View (E2)

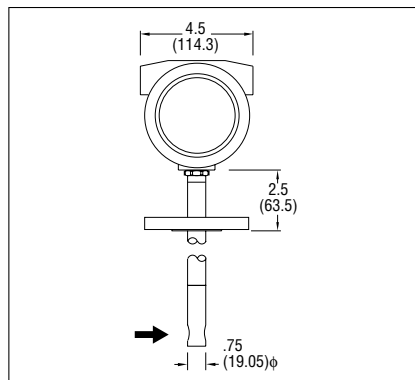

### Remote Mount Junction Box—Side View (E4)

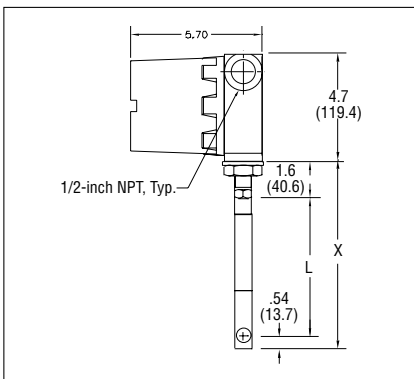

### Remote Mount Junction Box—Front View (E4)

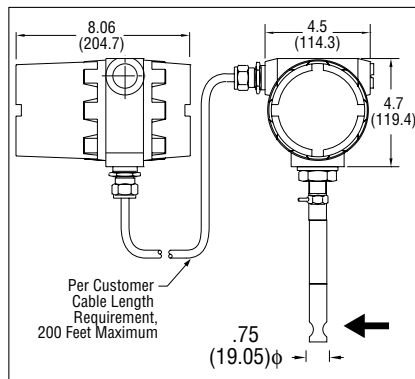

### Remote Mount—Side View (E3, ATEX only)

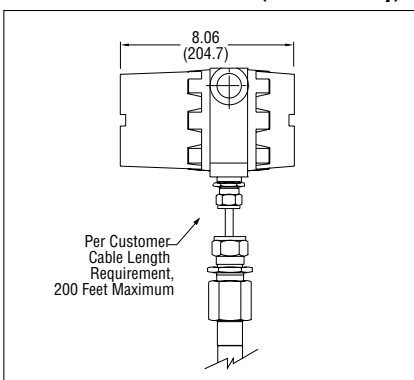

### Remote Mount—Front View (E3, ATEX only)

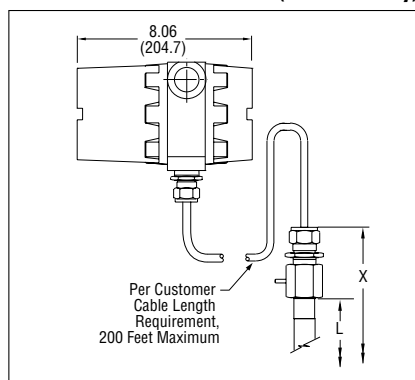

## Tables

Length Chart (Compressions Fittings)		
Code	L	X
L06	6.0 (152.4)	7.5 (190.5)
L09	9.0 (228.6)	10.5 (266.7)
L13	13.0 (330.2)	14.5 (368.3)
L18	18.0 (457.2)	19.5 (495.3)
L24	24.0 (609.6)	25.5 (647.7)
L36	36.0 (914.4)	37.5 (952.5)

Length Chart (Flange Mounting)		
Code	L	X
L06	6.0 (152.4)	9.0 (228.6)
L09	9.0 (228.6)	12.0 (304.8)
L13	13.0 (330.2)	16.0 (406.4)
L18	18.0 (457.2)	21.0 (533.4)
L24	24.0 (609.6)	27.0 (685.8)
L36	36.0 (914.4)	39.0 (990.6)

Length Chart (Remote Mount Junction Box)		
Code	L	X
L06	6.0 (152.4)	7.5 (190.5)
L09	9.0 (228.6)	10.5 (266.7)
L13	13.0 (330.2)	14.5 (368.3)
L18	18.0 (457.2)	19.5 (495.3)
L24	24.0 (609.6)	25.5 (647.7)
L36	36.0 (914.4)	37.5 (952.5)

### Mounting Holes for Remote Bracket

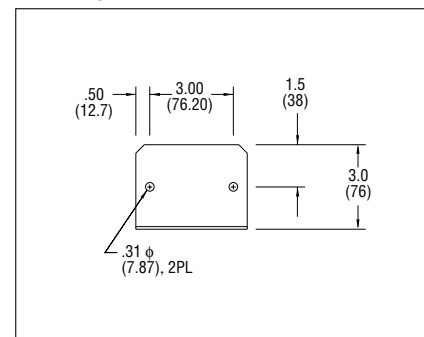

## Hazardous-Area Location Enclosure Dimensional Specifications

### Remote Rear Bracket Mounted Electronics

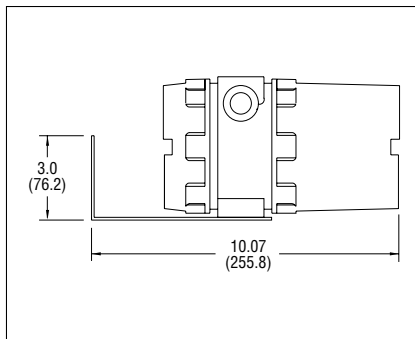

### Remote Side Bracket Mounted Electronics

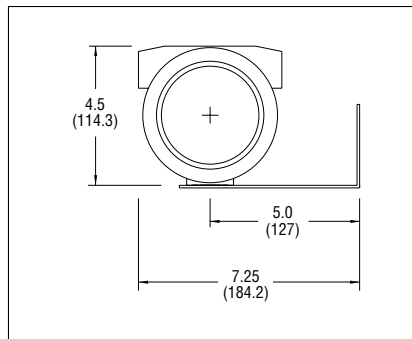

## Tables

Length Chart (NEMA 4X)		
Code	L	X
L06	6.0 (152.4)	7.25 (184.1)
L09	9.0 (228.6)	10.25 (260.3)
L13	13.0 (330.2)	14.25 (361.9)
L18	18.0 (457.2)	19.25 (488.9)
L24	24.0 (609.6)	25.25 (641.3)
L36	36.0 (980.4)	37.25 (946.1)

## NEMA 4X Dimensional Specifications

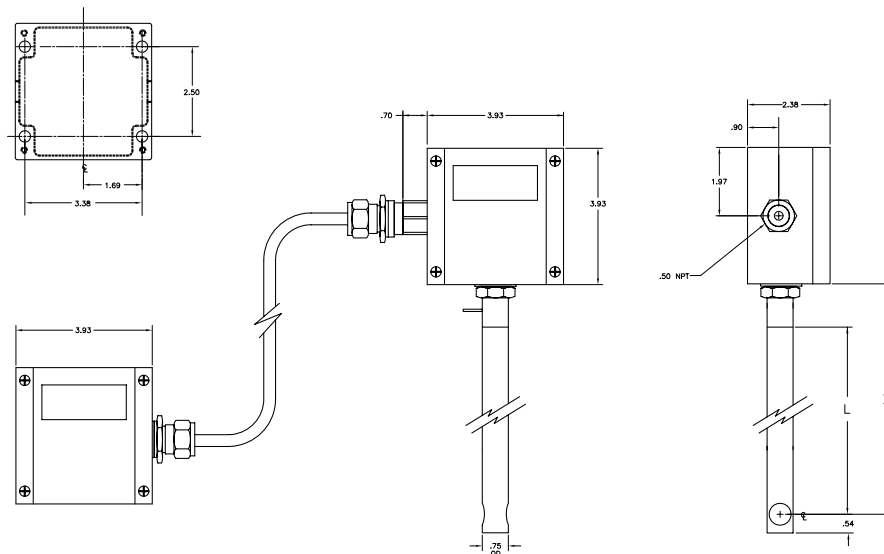

## Self-Cleaning Purge Option

- Maximum process pressure 100 Psi
- Maximum process temperature 500 F.
- Max pressure purge air: 150 Psi
- Process connection Purge air 1/4" NPTF
- Wetted Process Parts: all 316SS
- The purge gas must be clean and dry. Do not use a liquid to clean the sensor inline
- The purge system is only available with E4 and E2 housings
- The purge system is NOT available with FM, ATEX or CSA approval or the high temperature option

**Warning:** During the purge cycle there will be a high flow over the sensor. This will drive the output of the flow meter to the maximum flow (Output will be 20-26 mA (I

**Operation:** This is not a continuous flow of air, but a blast purge option. The purge nozzle creates a jet stream which blows deposits from the sensors. The frequency and intensity of the purge is determined by the end user. It can be done with a suitable manual, pneumatic or electric valve (Solenoid). It is also possible to control the purge system automatically (f.i. timer, PLC or HMI).

**Note:** There is a check valve built inside the flow meter to prevent the return flow of process gases into the purge system. Replacement of this valve can only take place in the factory.

## Low Pressure Hot Tap to 150 psig (10 barg)

### Side View

#### VARIABLES

L = Nominal Probe Length

D = Duct O.D.

C = Duct I.D.

T = Height of "Threadolet" or Customer Provided Weldolet

R = Restraint Cable Length

#### FORMULA

$$L \geq 12 + D/2 + T$$

So L must be equal or greater than 12-inches plus the height of the "Threadolet" plus half the duct O.D.

$$R = D/2 + T + 8.8$$

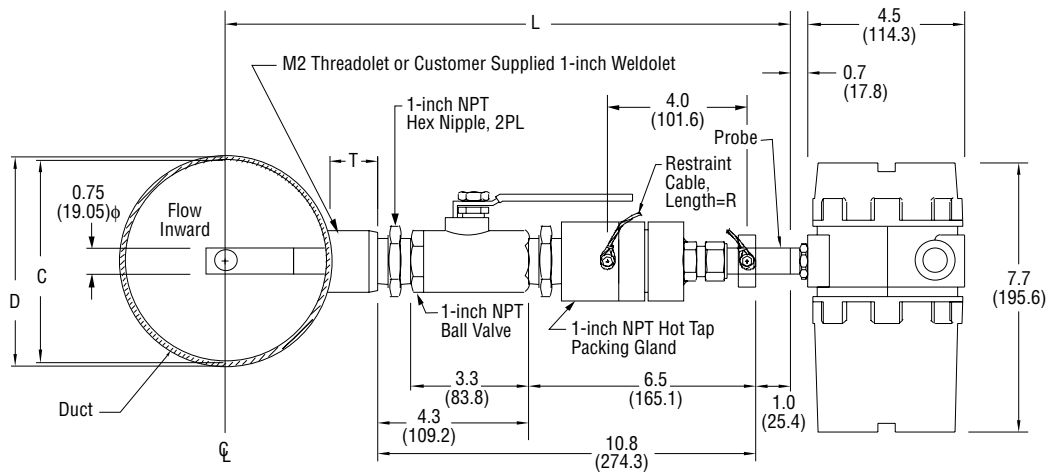

All dimensions are inches. Millimeters are in parentheses. All drawings have a +/- .25-inch (6.4 mm) tolerance. Certified drawings are available on request.

## High Pressure Hot Tap to 1000 psig (70 barg)

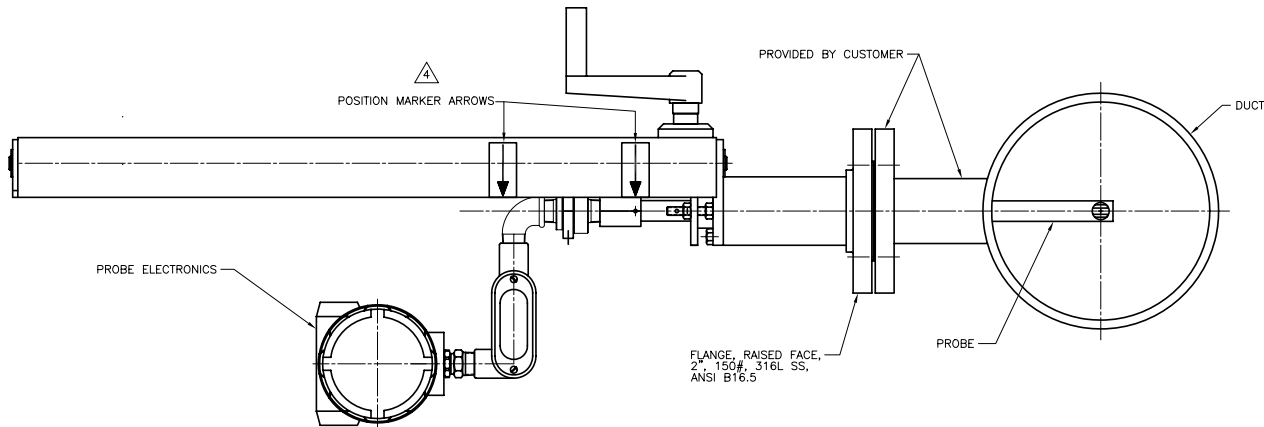

## Unobstructed Flow Requirements

Select an installation site that will minimize possible distortion in the flow profile. Valves, elbows, control valves and other piping components may cause flow disturbances. Check your specific piping condition against the examples shown below. In order to achieve accurate and repeatable performance install the flow meter using the recommended number of straight run pipe diameters upstream and downstream of the sensor. If you cannot meet these requirements please refer to the Flat-Trak™ Model 780S with flow conditioning plates (flow conditioning plates reduce upstream requirements to as little as 2 diameters).

### Example A – Upstream (1) Requirements

1	15D
2	20D
3	40D
4	15D
5	30D
6	40D

(1) Number of diameters (D) of straight pipe required between upstream disturbance and the flow meter.

### Example B – Downstream (2) Requirements

1	5D
2	5D
3	10D
4	5D
5	10D
6	5D

(2) Number of diameters (D) of straight pipe required downstream of the flow meter.

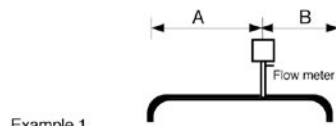

Example 1. One 90°elbow before meter

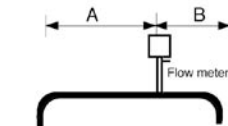

Example 2. Two 90°elbows before meter in one plane

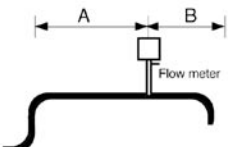

Example 3. Two 90°elbows before meter out of plane (if three 90°bends present, double recommended length)

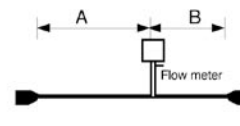

Example 4. Reduction before meter

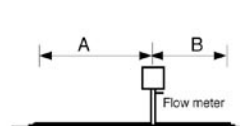

Example 5. Expansion before meter

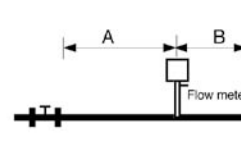

Example 6. Regulator or valve partially closed before meter (If valve is always wide open, base length requirements on fitting preceding it)

## Performance Specifications

### Accuracy of Point Velocity

+/- 1% of reading + 0.5% of full scale

### Repeatability

+/- 0.2% of full scale

### Temperature Coefficient

+/- 0.02% of reading per °F within +/- 50° F of customer specified conditions

+/- 0.03% of reading per °F within +/- 50° F to 100° F of customer specified conditions

+/- 0.04% of reading per °C within +/- 25° C of customer specified conditions

+/- 0.06% of reading per °C within +/- 25° C to 50° C of customer specified conditions

### Pressure Coefficient

.02% per psi for air, consult factory for other gases

### Response Time

One second to 63% of final velocity value

## Operating Specifications

### Gases

Most gases compatible with 316 L stainless steel

Hastalloy® available

### Gas Pressure (2 limitations)

Mechanical design pressure:

Compression fittings: 500 psig (34 barg)

1-inch 150 lb flange (-40° to 250° F): 185 psig (12.8 barg)

Low Pressure Hot Tap: 150 psig (10 barg)

High Pressure Hot Tap: 1000 psig (70 barg)

### Pressure Drop

Negligible for pipes three inches in diameter or larger

### Gas & Ambient Temperature

Gas ..... -40° F to 350° F (-40° C to 177° C) Gas dependent.

Ambient ..... -40° F to 120° F (-40° C to 50° C)

### Leak Integrity

$5 \times 10^{-9}$  cc/sec of helium maximum

### Power Requirements

18 to 30 VDC (regulated), 625 mA maximum

100 to 240 VAC, 50/60 Hz, 15 watts maximum

## High Temperature Option

Up to 750° F (400° C) air only; consult factory for other gases

## Digital Communications Options

Foundation Fieldbus (read only; flow and totalized flow)

Profibus PA (read only; flow and totalized flow)

MODBUS RTU (read/write most parameters)

RS-232 (standard; command set available)

## Output Signal

Linear 0–5 VDC or 0-10 VDC, 1000 ohms minimum load resistance or

Linear 4–20 mA proportional to mass flow rate,

700 ohms maximum resistance power supply dependent

User-selectable: Active non-galvanically separated or Passive galvanically separated (loop power required)

## Alarms

Hard contact user-adjustable high and low

Dead band adjustable with Smart Interface™ software

Relay ratings: Maximum 400 VDC or VAC (peak), 140 mA

## Displays

Alphanumeric 2 x 12 digit backlit LCD

Adjustable variables via on-board switches (password protected)

or with Smart Interface™ software

Adjustable variables: Full scale (50 to 100 %)

Time Response (1 to 7 seconds)

Correction factor setting (0.5 to 5)

Zero and span

High and low alarm settings

## Totalizer

Seven digits (9,999,999) in engineering units

Resettable by software, on-board switches or external magnet

## Software

Smart Interface™ Windows®-based software

Minimum 8 MB of RAM, preferred 16 MB of RAM

RS-232 communication

Additional features: Alarm dead band adjustment

Zero cut-off adjustment

Linearization adjustment

Save / Load configurations

Flow meter validation

## Physical Specifications

### Wetted Materials

316L stainless steel

### Enclosure

Hazardous-Area Location Enclosure (IP66) or NEMA 4X (IP65)

Both are powder-coated cast aluminum

### Electrical Connections

Two 3/4 inch NPT: Hazardous-Area Location Enclosure (IP66)

One 1/2 inch NPT: NEMA 4X Enclosure (IP65)

### Mounting (optional)

ANSI 1-inch 150 lb flange

3/4-inch tube compression fitting with 1-inch male NPT

Hot tap systems

### Certifications

CE (All enclosures)

CSA (Explosion proof for Class I, Division 1, Groups B, C, D)

ATEX ( II 2 GD Ex d IIC T6 ... T2; IP 66 T70 °C ... T280 °C )

FM (Explosion proof for Class I, Division 1, Groups B, C, D; dust-ignition proof for Class II, III, Division 1, Groups E, F, G)

IP65, NEMA 4X T6 -40° C to 70° C ambient

Chinese pattern approval

GOST R/RTN (1ExdIIC T6...T2)

# Ordering the Model 640S

